

CV Series for 115 Vac or 115/230 Vac Dual Voltage Capacitor Start Motors

[BACK TO TABLE OF CONTENTS](#)

Basic Operation

Capacitor start motor require a method to extract speed data from the voltage across the motor start winding. By comparing the start winding RPM-sensitive voltage with the main AC input voltage (which serves as a reference voltage), the switch determines when the start circuit should be energized. The electronic switch interrupts the start circuit current after the motor has accelerated to the cut out speed, and reconnects the start circuit whenever the motor speed has fallen to cut in speed (usually about 50% of synchronous motor speed).

- ① **Electrically Protected.** Designed to filter out electrical noise, so there is no concern of random switch malfunction.
- ② **Reduced Installation Time.** Easily accessible 1/4 inch terminals and mounting, reduce the amount of time required to install SINPAC Switches or to change out mechanical switches.
- ③ **Restart Capability.** When motor speed drops below 50% of synchronous speed, the start circuit is reconnected to reinitiate starting torque.
- ④ **Soldered Heat Sink.** High cycling.
- ⑤ **Transient Protection.** Transient protection tested per IEEE C62.41 - 1991 Category A3.
- ⑥ **Universal Design.** 50/60 Hz operation. Will work on 2, 4 or 6 pole motors of any manufacturer. Reduced inventory.
- ⑦ **Line Voltage Compensation.** No modifications or changes are required for line voltage variations. SINPAC Switches will operate in areas susceptible to *brown-outs* or low voltage due to long wiring runs. It also means there will be less stress on the starting capacitor due to over voltage.



ADDITIONAL FEATURES

- **UL Recognition (E71115) to US and Canadian Standards**
- **Operating Temperature:** -40°C to 65 °C (-40 °F to 149°F) [for operation between 65°C and 85°C (149°F and 185°F), consult factory.]
- **Operating Voltage:** 115 Vac SINPAC Switch: 90-130 Vac. For dual voltage motor equipped with center-tapped main winding: 90-130 Vac or 180-265 Vac.

-11 Enclosure

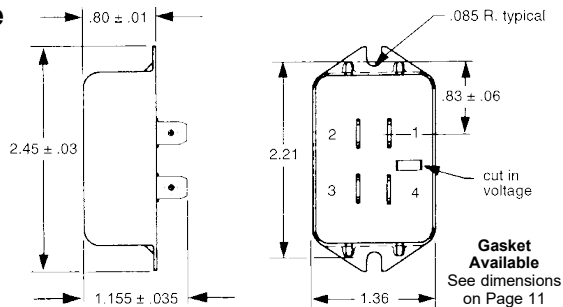

Gasket -11 Enclosure

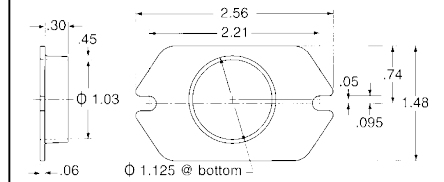

-12 Enclosure 50-amp Switch

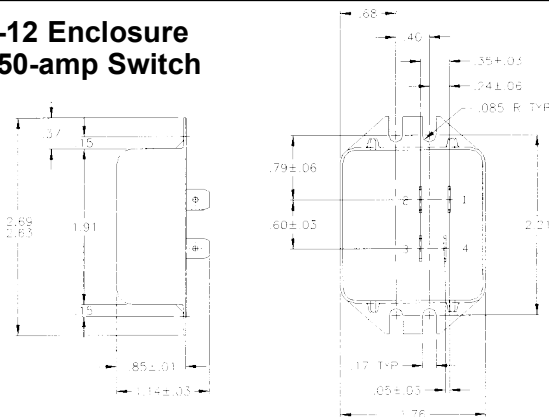

Gasket -12 Enclosure

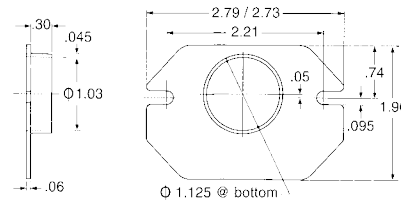

Dimensions are for estimating only. Drawings for customer reference are available upon request.

Typical Maximum Motor hp	Typical Full Load Motor Nameplate Current Rating (amps)		Switch Rating and Permissible Maximum Start Capacitor Current (amps)	Start Circuit Voltage	Catalog Number	Part Number	Cut Out Voltage Typical	Cut In Voltage Typical	Package Style
	115 Volts	115/230 Volts							
2	20	20/10	40	115	CV-40-130	4-7-21040-11-UA3	130	30	11
2	20	20/10	40	115	CV-40-147	4-7-21040-11-UB3	147	37	11
2	20	20/10	40	115	CV-40-165	4-7-21040-11-U03	165	37	11
3	25	25/12.5	50	115	CV-50-165	4-7-21S50-12-U03	165	37	12
3	25	25/12.5	50	115	CV-50-180	4-7-21S50-12-UD3	180	50	12

Selection

Motor hp ratings are typical. For an accurate selection procedure, measure start capacitor current during a normal start or at locked rotor and select a SINPAC Switch with higher maximum current rating than that measured.

1. Be sure switch series matches motor type.
2. Be sure switch voltage rating matches (start) circuit voltage rating.
3. Selection can be based on actual measurement of start capacitor current or two times the motor nameplate FLA rating.
4. Switch current rating must match or exceed the motor start capacitor requirements. Always select a SINPAC Switch with the next higher current rating for:
 - a) High cycling applications.
 - b) Long acceleration time.
 - c) High ambients: Greater than 55° C.
5. To assure proper motor operation, the voltage across the start winding must reach the SINPAC Switch cut out reference voltage between 70% to 85% of motors synchronous speed.

Caution: SINPAC Switches are line voltage compensated. Changes in the line voltage will not effect system operation unless an overload condition causes reduced running speed, along with reduced voltage across the start winding.

6. Higher current switches can be used in place of lower rated switches of the same series.

Wiring Diagram

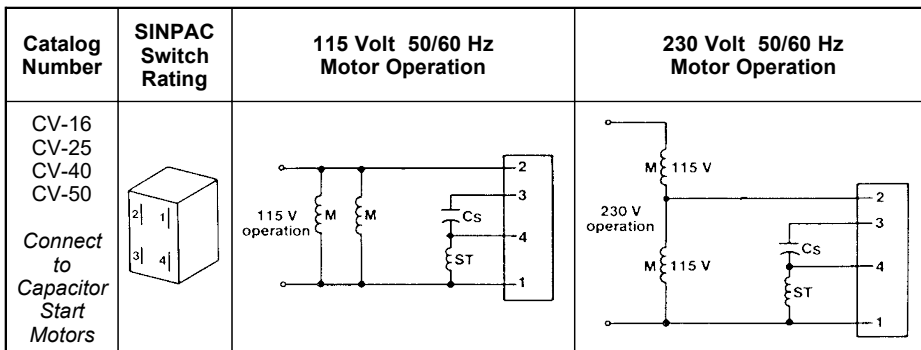

Cs – Start Capacitor, M – Motor main winding, ST – Motor start winding

Line Voltage Compensation Charts

Induced voltage across the start winding is directly proportional to motor speed and line voltage. All SINPAC Switches use this voltage to switch the start capacitor out of the circuit. Your motor with a SINPAC Switch must generate a voltage that is 20% greater than the switch cut out voltage to assure cut out of the start capacitor. Refer to charts below.

