



QUICK TURN NEXUS SERIES

SPEED, POWER AND PRECISION

QUICK TURN NEXUS SERIES

Featuring several technological innovations and a diverse machine selection, the QUICK TURN NEXUS Series of 2-axis and Multi-Tasking CNC Turning Centers delivers speed, power and precision for exceptional performance in virtually any turning operation.

In fact, the series, consisting of seven models in more than 20 different configurations, provides unmatched productivity and reduced cycle times across a wide range of workpiece geometries, from the very simple to the highly complex, and sizes from smaller, shorter parts to long, large-diameter shaft-type parts.



QUICK TURN NEXUS 250-II MS



QUICK TURN NEXUS 450-II MY W/LVM

FEATURES AND BENEFITS

QUICK TURN NEXUS machines deliver unmatched productivity and the industry's shortest part cycle times.

- Standard high-powered, integral main turning spindles support heavy-duty machining
- Upper turrets with rotary tool spindles and Y-axis capability provide Multi-Tasking machine functionality for milling, turning and drilling operations as well as difficult and specialty threading, including API
- Second turning spindles add Done-In-One® part processing
- Chuck sizes from 6" to 21" in diameter support multiple workpiece dimensions
- Optional rear chucks provide additional workpiece support
- A wide range of work envelopes and bed lengths accommodates various part sizes
- Built-in CNC programmable tailstocks increase cutting rigidity
- Long boring bars provide deep-hole boring in heavy-duty applications
- Long vertical mills enable deep-hole I.D. milling and drilling in heavy-duty applications
- Mazak MX Hybrid Roller Guide Systems deliver durability and reliability for long-term accuracy
- Tool Eye Systems quickly and automatically measure tool tip positions to detect tool wear and damage
- Automatic steady rests enhance process stability when machining long, large-diameter parts
- CNC controls offer easy programming, fast job setup and increased accuracy

QUICK TURN NEXUS LINEUP

- QUICK TURN NEXUS 100-II MS, MSY, MY
- QUICK TURN NEXUS 200-II M, MS, MSY, MY
- QUICK TURN NEXUS 250-II M, MS, MSY, MY
- QUICK TURN NEXUS 300-II M
- QUICK TURN NEXUS 350-II M, MSY, MY
- QUICK TURN NEXUS 400-II M, MY
- QUICK TURN NEXUS 450-II M, MY, MY w/LBB, MY w/LVM

MACHINE CONFIGURATIONS

- M = Upper turret with rotary tool milling
- S = Second spindle
- Y = Y-axis capability
- LBB = Long Boring Bar
- LVM = Long Vertical Mill



ADVANCED HEADSTOCKS

POWER AND RIGIDITY

Advanced integral spindle/motor headstocks, with spindle cooling capabilities, deliver increased spindle rigidity for heavy-duty machining and high-speed, high-torque performance.

The design (see photo A) uses no belts or pulleys, resulting in zero backlash. Powerful variable-speed AC inverter motors directly drive headstock spindles.

A full-circumference C-axis headstock brake design (see photo B), as opposed to automotive-type caliper brakes, provides high-accuracy positioning to within 0.0025 mm (0.0001").

Headstock cooling systems (see photo C) further ensure stable continuous precision machining by maintaining constant headstock temperatures.



A. No belt or pulley



B. Full-circumference C-axis headstock



C. Headstock cooling system

SPINDLE SELECTION

MACHINING VERSATILITY

Main spindles feature through-bore sizes of 51 mm (2.0"), 77mm (3.0"), 132 mm (5.2"), 185 mm (7.2") and 259 mm (10.2") – the world's first "Big Bore" integrated motor spindle.

Maximum spindle speeds from 2,500 rpm to 6,000 rpm with maximum horsepower ratings from 15 to 50 make it possible to machine a wide range of materials as well as part shapes and diameters.

Achieve part processing versatility using machine spindles for C-axis indexing in 0.0001-degree increments for accurate part positioning and contouring capability.

FULL-FUNCTION TURRETS

STANDARD 2-AXIS CAPABILITY

Rigid non-lift, 12-position drum turrets reduce machine non-cut times in 2-axis operations via extremely fast indexing speeds. These turrets feature the shortest route random tool selection in automatic mode, while indexing forwards and backwards in manual mode.

MULTI-TASKING CAPABILITY

Shorten part-processing cycle times through Multi-Tasking functionality achieved with the addition of live milling capability in X/Y-positioning non-lift, servo-driven 12-position dodecagonal drum turrets for VDI-type tool holders.

The turret allows static and rotary tools with VDI-type shanks to be mounted in any position. And unlike bolt-on designs, the Mazak VDI turret makes it possible to change tools, together with tool holders, in one operation.

Hydraulically clamped and unclamped with a force of 8,264 kg (18, 180 lbs.), the turret quickly indexes at speeds of 0.25sec/1step, 0.8 sec/6 steps, driven by the AC servomotor.

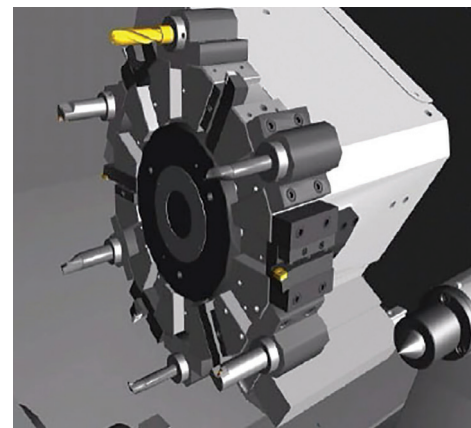

Standard Turret

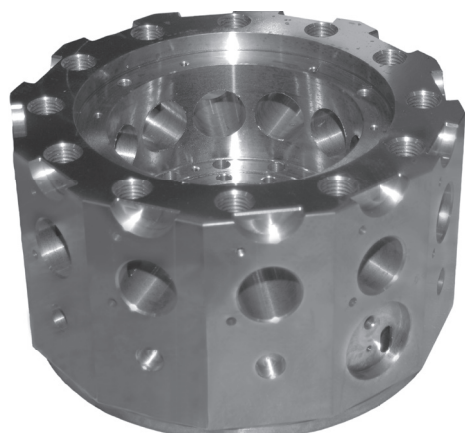

Machined VDI Turret

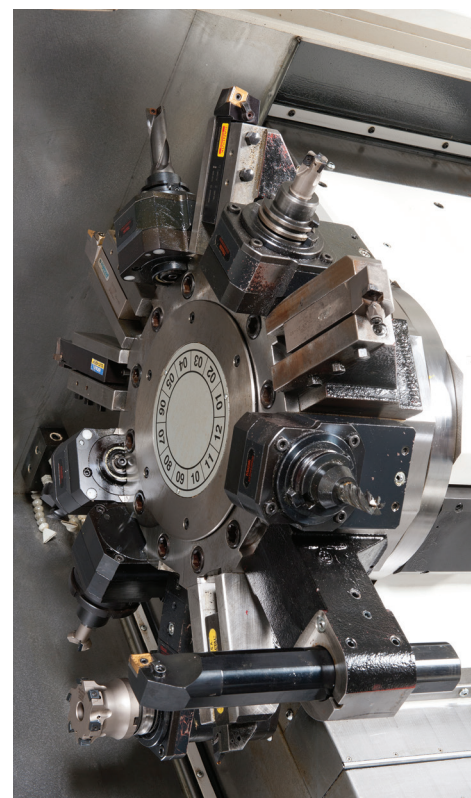

Multi-Tasking Turret

AC SPINDLE MOTORS

FAST AND EFFICIENT MILLING

Rated at 5.5 kW (7.5 hp) and 7.5 kW (10 hp), with maximum speeds between 4,000 rpm and 6,000 rpm and torque ratings up to 9.7 kgf-m (70 ft-lbs), machine turret AC spindle motors on the various QTN models drive rotary tools with power and speed for fast and efficient metal removal and for Y-axis off-center operations.

Y-AXIS TURRET MOTION

RIGID AND PRECISE

A rigid, double-slide Y-axis construction withstands the cutting forces generated by heavy-duty turning and milling operations. Benefit from a variety of added advanced capabilities such as keyway finishing and off-centerline O.D. drilling.

Generous Y-axis travels measure 100 mm (50 mm + 50 mm) (4" (2" + 2")), 150 mm (75 mm+75 mm) (6" (3" + 3")) and 200 mm (100 mm + 100 mm) (8" (4"+4")) and help shorten part cycle times with fast maximum cutting feedrates of 3.5 m/min [139 ipm] and rapid traverse speeds of 15 m/min (591 ipm).

REAR CHUCKS

LONG-PART STABILITY

Optional rear chucks, as part of the machine's main spindles, ensure secure and stable holding for accurate long bar and shaft machining operations, such as those in energy industry work.

As with the main spindles, rear chuck through-holes can measure up to 259 mm (10.2") in diameter. For operator safety, a hinged cover grants easy access for the set-up and changing of rear chucks. The cover is also safety interlocked.

While the rear chuck is an available option for the QTN 350-II and 400-II models as well as the 450-II M, it comes standard on the QTN 450-II MY models.

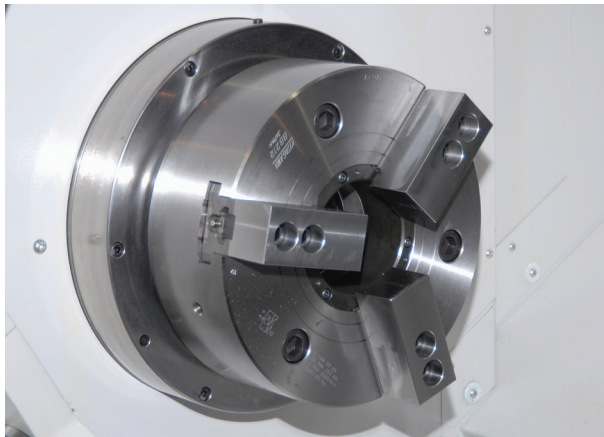

POWERFUL TORQUE AND LONG BED LENGTHS

HEAVY-DUTY LARGE-PART MACHINING

Achieve aggressive turning performance in high metal-removal applications with a powerful machine torque of 243.19 kgf-m (1,760 ft-lbs) offered with the QTN 400 and 450 machines.

Accommodate long large parts in machine bed lengths of 2,000 mm (80") and 3,000 mm (120") and in chuck sizes of 304.8 mm (12"), 457.2 mm (18") and 533.4 mm (21"). Process parts up to 580 mm (22.84") in diameter with QTN 400-II and 450-II maximum machine swings of 840 mm (33.0").

CNC PROGRAMMABLE TAILSTOCK

PRECISE SUPPORT

CNC programmable tailstocks provide simple, precise and automatic control of the Z-axis directional movement and thrust force settings. The electronic AC servomotor and ballscrew-driven tailstocks generate consistent holding pressure for supporting long heavy workpieces to ensure consistent high-accuracy turning.

The standard tailstock design provides optimum clearance when using large steady rests. Equipped with built-in centers, the tailstocks provide fast and safe movement with high- and low-speed capabilities.

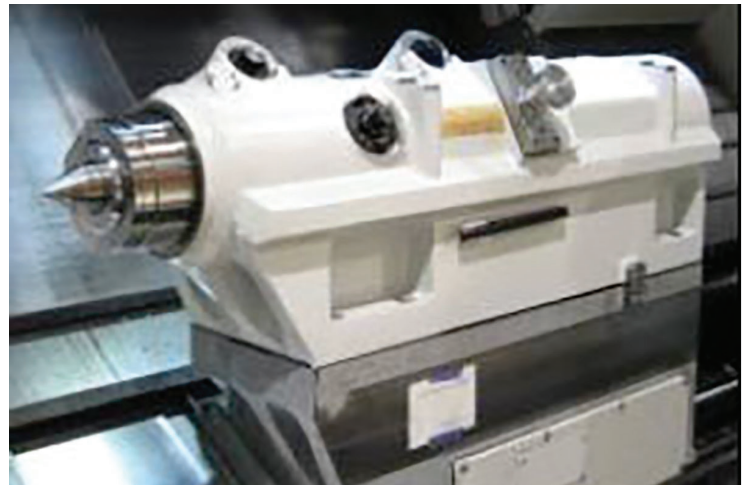

LONG VERTICAL MILL (LVM) TAILSTOCK

DEEP-HOLE I.D. MILLING AND DRILLING

Featuring a 1,150 mm (45.27") boring bar with a special bolt-on angle head, the optional LVM combination headstock provides deep-hole boring to depths of 1,039 mm (40.9") and performs inside diameter milling operations, such as internal keyways and internal drilling inside long, large-diameter shaft-type workpieces.

LONG BORING BAR (LBB) TAILSTOCK

DEEP-HOLE BORING

Equipped with a bull nose center and 1,016 mm (40") boring bar, the optional LBB combination tailstock allows for deep-hole boring to depths of 800 mm (31.5") on long, large-diameter shaft-type workpieces.

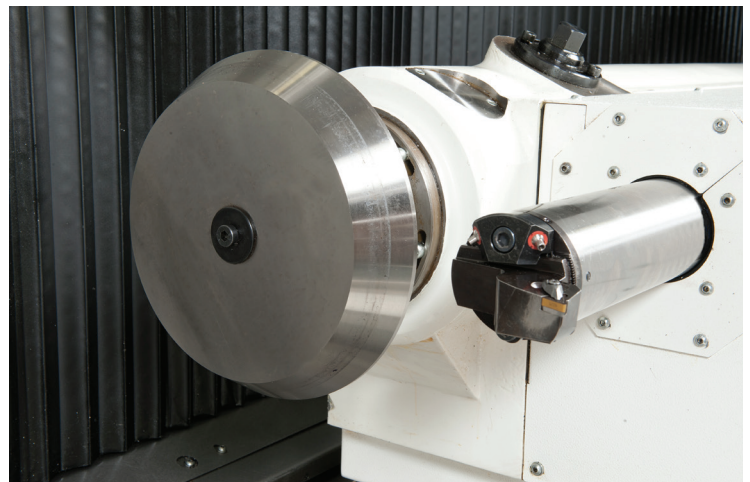

MAZAK MX HYBRID ROLLER GUIDE

FASTER SPEEDS AND IMPROVED ACCURACY

Mazak MX Hybrid Roller Guide Systems allow for faster speeds and boost accuracy, leading to a comprehensive improvement in overall machine productivity and profitability. When compared to traditional ball guides and boxways, the advantages of the Mazak MX Hybrid Roller Guide System are clear.

- More surface contact for large load capacities and better dampening
- Better distribution load points via an X-design that allows load to be applied in four directions
- Higher positioning accuracy than boxways due to no stick and slip
- Faster and greener than boxways with nearly twice the rapid traverse rate and less contamination in the coolant system

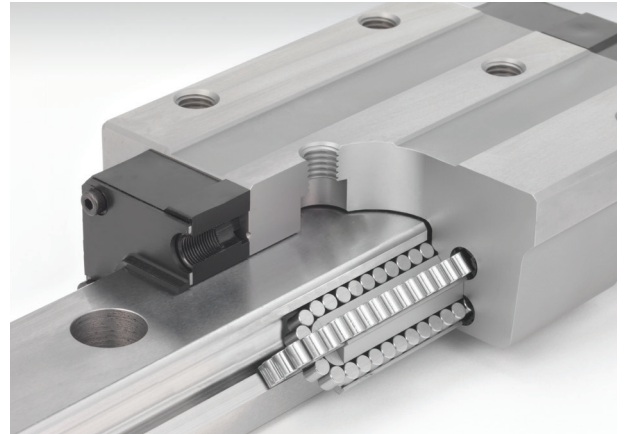

TOOL EYE

QUICK AND EASY TOOL SETUP

Tool Eye Systems on the QTN machines quickly and automatically measure tool tip positions to detect tool wear and damage, ensuring part accuracy during continuous machining operations.

The system measures in four directions (+X, -X, +Z and -Z) and the resulting positioning data automatically transfers to the machine's NC memory. At which point, conventional test cutting and program editing are no longer necessary for tool tip position measuring. Therefore, machining resumes almost instantaneously after a tool change.

In the event of tool wear, the Tool Eye provides data for the automatic correction of the machining programs so that unattended operations continue running without interruption. And when the Tool Eye detects tool damage, machine operation can come to a stop.

■ TOOL SETUP CHANGING

Automatic storage of tool data into the NC memory is accomplished by bringing the tool nose into contact with the Tool Eye sensor. Thus, conventional test-cutting or program-editing for measuring the tool nose position is no longer necessary.

■ TOOL TIP CHANGING

When the tool tip is changed for a new one, machining can be immediately restarted since fully automatic tool nose measurement becomes possible.

■ WEAR CORRECTION

The results of tool nose wear detection can be used to correct the program. Fixed machining dimensions can therefore be maintained even during unattended operation.

■ TOOL DAMAGE DETECTION

Operation can stop when tool nose damage is detected.



STEADY REST

STRONG PART SUPPORT

An optional automatic steady rest makes for the reliable, safe and accurate machining of long, large-diameter workpieces. It also enhances turning process stability when the QTN machine is cutting in the Y-axis or during milling operations.

QTN machines can accommodate up to K5 steady rests with capacities for part diameters from 60 mm (3.15") to 390 mm (13.35"). The steady rests ride on their own independent bases to position automatically at servomotor-driven speeds of 8 m/min (314.8 ipm) and feature full hydraulically powered rests that also automatically open and close around workpieces.



ERGONOMIC DESIGN

EASE OF MAINTENANCE

Items on QTN machines that require frequent access and/or routine maintenance attention are conveniently located in one central location. CNC panels are strategically positioned to ensure optimum visibility and ease of operation, while coolant tanks can be pulled out from the front of the machines for easy cleaning. Standard color-coding of cables allows for easy identification and convenient maintenance.

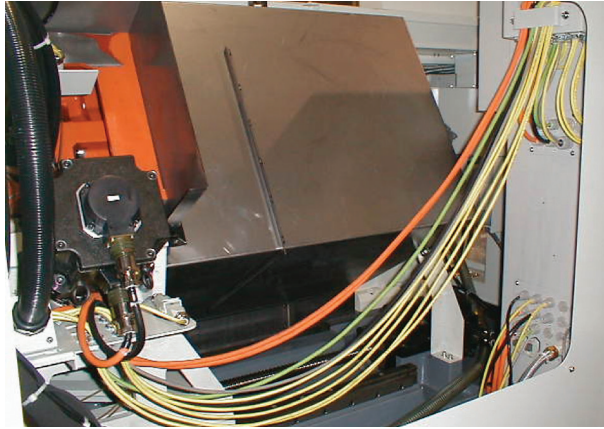

MACHINE OPTIONS

FOR ALL PRODUCTION NEEDS

Through-hole chuck packages	18" (2,000 rpm, 4.5" bar capacity), 18" Big Bore (2,000 rpm, 6.5" bar capacity), 21" (1,700 rpm, 5.5" bar capacity)
Air chuck packages	Available to accommodate spindle bore size.
Automatic chuck jaw operation	Simple program M-codes automatically open or close machine chuck jaws. Capability is in addition to standard foot switch chuck operation.
Coolant temperature control	Avoid thermal affects on machining accuracy. Coolant chiller unit keeps machine coolant at ambient room temperature, further ensuring maintained machining accuracy over extended periods of operation.
High-pressure coolant	High-pressure coolant system optimizes chip removal and dissipates heat. Coolant discharge pressure is rated at 2.4/3.5 kgf (34/50 psi) with discharge volume of 20 L/min (0.7 ft3/min).
Additional headstock coolant nozzle	Discharge added coolant from a nozzle located in the upper portion of machining area to minimize heat generated by cutting and to remove chips from machine chuck and workpieces.
Turret air blast	Alternately use flood coolant nozzles for air blasting chips away during machining operations.
Chip conveyor (hinge-type side disposal)	Efficiently evacuate chips by way of hinge-plate belt from side of machine.
Overload detection	For prolonging tool life and unmanned operations, detector system continuously monitors spindle motors and servomotors. Machine will be quickly stopped if pre-set limits are exceeded during automatic operations.
Mist collector	Maintain safe and clean work environments by removing mist coolant or oil from machine work envelopes. System is most effective when coolant pressures are above 15 kgf/cm2 (213 psi).
Automatic power breaker on/off by breaker trip	Breaker automatically shuts off all power after machining has stopped. Machine's main power breaker also turns off three minutes after machining finishes.
Automatic power control by calendar timer	Use machining programs to automatically turn machine power off or on for efficiently warming up all axis components (X, Y, Z, main spindle, milling spindle, etc.) to optimum operating temperatures.
Three-color machine status light	Receive instant visual alerts of machine status indicated by red for alarm, yellow for machining completion, and green for automatic operation.
Automatic front door	Automatically open machine front doors when a cycle start is commanded or by using M-codes in the case of unmanned operations with automation. Servos operate automatic door motion, and for manual operation, two buttons must be pushed simultaneously to open or close doors for operator safety.
Bar feeders	Machines can be supplied with all the necessary features to readily accept bar feeders, making for easy system installation. Intent for bar feeder use must be conveyed during order process to ensure machines are prepared well in advance of delivery.
High/low chuck pressure	Program M-codes automatically change machine chuck pressure to effectively machine various types of workpieces requiring frequent clamping pressure changes.
Workpiece measurement function	With a touch probe, a sensor unit automatically measures workpiece I.D.s and O.D.s and other surface features to maintain machining accuracy during unattended operations.

MATRIX NEXUS 2 CNC CONTROL

EASY PROGRAMMING, OPTIMIZED PERFORMANCE

- QUICK TURN NEXUS 100 MY
- QUICK TURN NEXUS 200 MY
- QUICK TURN NEXUS 250 MY
- QUICK TURN NEXUS 300 MY
- QUICK TURN NEXUS 350 MY
- QUICK TURN NEXUS 400-II MY (2,000)
- QUICK TURN NEXUS 400-II MY (3,000)
- QUICK TURN NEXUS 450-II MY (2,000)
- QUICK TURN NEXUS 450-II MY (3,000)

The MATRIX NEXUS 2 CNC control simplifies metalworking operations. With unequalled innovation for conversational programming, the control incorporates a wide variety of advanced features for increased productivity through high-speed, high-accuracy machining.

MAIN FEATURES AND BENEFITS:

HARDWARE

- Simultaneous control of up to 3 axes and continuous control of second spindles
- 20GB hard disk offers increased program storage capacity
- High-speed CPU and large 12.1" CNC display supports multiple functions
- EIA/ISO and conversational programming offers versatility and user-friendly operation
- Sub-micron input and nano control delivers high accuracy machining

SOFTWARE

- Intelligent Thermal Shield provides heat displacement control for improved stability
- Active Vibration Control reduces vibration for high accuracy positioning
- Intelligent Safety Shield offers safe operation during machine set up and manual operation
- Mazak Voice Adviser provides verbal support for machine set up and safety
- Control functions streamline data entry and reduce programming time
- Virtual machining provides convenient program and interference checks



MATRIX NEXUS 2 CNC CONTROL SPECIFICATIONS

	MATRIX NEXUS	EIA / ISO
Number of controlled axes	Max. 3 axes (simultaneous 3 axes)	Max. 3 axes *(simultaneous 3 axes)
Least input increment	0.0001mm, 0.00001inch, 0.0001°	
Max. programmable value	±99999.9999mm, ±9999.99999inch, ±99999.9999°	
High-precision control	Smooth high gain control, Scale feedback, Absolute position detection	
MAZACC-2D	*Shape error designation, *Rotational-shape correction	
MAZACC-3D	–	*High-speed feedrate for contour defined in small program increments
Interpolation	Positioning (Independent axes control, Linear interpolation), Linear interpolation, *Synchronized milling spindle tapping	Polar coordinate interpolation, *Cylindrical coordinate interpolation, *Polygon cutting *Thread cutting (equal pitch, variable pitch)
Feed function	Rapid traverse, Cutting feed (per revolution, per minute), Feedrate clamp, Override (Rapid traverse, Cutting feed, External override, 2nd override, Override cancel) Automatic acceleration/deceleration feedrate (Linear acc./dec., Time constant), Constant tangential speed control, Dry run	
Multi-Tasking machine control	Continuous control of 2nd spindle, In-phase matching, Axes torque control	*Tool-tip point control, *3-dimensional tool compensation
Program registration	256, *512, *960 2MB, *8MB(user area 7.7MB)	
Display	12.1 inch color SXGA TFT	
NC display languages	English, German, French, Italian, Spanish, Dutch, Norwegian, Swedish, Finnish, Danish, Portuguese, Turkish, Polish, Czech, Romanian Chinese (simplified), Chinese (traditional), Korean, Slovakian, Russian, Hungarian, Japanese (simplified language switching)	
Windows languages	English, Chinese (simplified / traditional), Korean, Russian, Japanese (Selection)	
Data Input / Output	USB, IC memory card	
Protocol	*MAZAK protocol, Network protocol	
Interface	Card BUS, Ethernet (1000BASE-TX)	
Spindle function	S-code output (8-digit binary output, Analog output, Actual revolution speed binary output), Constant surface speed, Spindle revolution control (RPM clamp, High speed indication / speed change detection, Rotary speed display), Spindle override (0 - 150 %)	
Tool function	T-code output (8-digit binary data, next tool, used tool), Tool life monitoring (Number of workpieces, Time and wear compensation) Spare tool exchange, Tool management (Group number, Pocket number)	
Tool compensation	Tool-tip R compensation, Tool-tip shape compensation, Tool position compensation, Tool wear compensation, Tool radius compensation	
Number of registered tools	Max. 4000	
Tool offset pairs	4000	
Miscellaneous functions	M-code output (M3 - digit), simultaneous output of four 3-digit M-codes, Second miscellaneous functions (B 3-digit output), High speed MSTB interface	
Coordinate system control	MAZATROL coordinate system	Machine coordinate system (Machine coordinate system, Machine coordinate system shift, Zero-point shift) Work coordinate system (Work coordinate system, Work coordinate system shift)
Manual operation	Rapid traverse, Cutting feed, Handle feed, Zero-point return, Manual control (machine lock, gear shift, barrier cancel), Manual spindle control (spindle start, stop, reverse, jogging)	
Automatic operation	Memory operation, MDI operation, Cycle start, NC reset, Single block, Feed hold, Single process, Optional block skip, Optional stop, Machine lock, Barrier cancel, Feed override, Spindle control, Dry run, Manual handle control, Tool path storage (TPS)	
	–	Hard disk memory operation, *Ethernet operation, *IC memory card operation
Background function	During automatic operation (Programming, Data input / output, Tool path check)	
Machine compensation	Backlash compensation, Pitch error compensation, Rotational axis pitch error compensation, Thermal distortion compensation	
Protection function	Emergency stop, Over travel, Barrier (stored stroke limit, chuck barrier, work barrier) Interlock (cutting start, axis interlock), Alarm, INTELLIGENT SAFETY SHIELD, (*1) Virtual Machining, MAZAK VOICE ADVISER	
Measuring function	Manual measurement (Tool set measurement, Z-offset measurement), Automatic measurement (Work offset measurement, Z-offset measurement, Tool-tip point measurement, External measurement), Measurement data printout, Constant compensation	

* : Option

*1: Cannot operate in background

MATRIX 2 CNC CONTROL

HIGHLY ADVANCED PROGRAMMING

■ QUICK TURN NEXUS 450-II MY (3,000 W/LBB/LVM)

The MATRIX 2 CNC control uses the latest technology to provide extremely fast processing speed, excellent cornering, superior part surface finishes and reduced cycle times. Through advanced hardware and software functionality, the control brings unbeatable accuracy and increased productivity to highly complex applications requiring Multi-Tasking operations, full simultaneous 5-axis machining and automation.

MAIN FEATURES AND BENEFITS:

HARDWARE

- 9-axis control capability
- High-speed CPU and panel layout allows for easy operation
- ASIC technology enhances processing performance
- EIA/ISO and conversational programming offers versatility and user-friendly operation
- 20GB hard disk offers increased program storage capacity
- Customized position 19" CNC display provides ample room for a large amount of data
- High-speed small increment processing
- 5-axis spline interpolation for shorter cycle times, smoother toolpaths and greater control of tool vectors
- Extended Card for connecting to field networks

SOFTWARE

- Intelligent Thermal Shield provides heat displacement control for improved stability
- Active Vibration Control reduces vibration for high accuracy positioning
- Intelligent Safety Shield offers safe operation during machine set up and manual operation
- Intelligent Maintenance Support prevents unexpected machine downtime
- Mazak Voice Adviser provides verbal support for machine set up and safety
- Control functions streamline data entry and reduce programming time
- Volumetric Error Compensation balances volumetric axis position errors
- Virtual machining provides convenient program and interference checks



MATRIX 2 CNC CONTROL SPECIFICATIONS

	MATRIX 2	EIA / ISO
Number of controlled axes	Max. 9 axes (simultaneous 4 axes)	Max. 9 axes *(simultaneous 5 axes)
Least input increment	0.0001mm, 0.00001inch, 0.0001°	
Max. programmable value	±99999.9999mm, ±9999.99999inch, ±99999.9999°	
High-precision control	Smooth high gain control, Scale feedback, Absolute position detection	
MAZACC-2D	*Shape error designation, *Rotational-shape correction	
MAZACC-3D	–	*High-speed feedrate for contour defined in small program increments
Interpolation	Positioning (Independent axes control, Linear interpolation), Linear interpolation, *Synchronized milling spindle tapping	
	–	Polar coordinate interpolation, *Cylindrical coordinate interpolation, Helical interpolation, *Polygon cutting, *Hobbing, Thread cutting (uni-pitch, variable pitch), *5-axis spline interpolation
Feed function	Rapid traverse, Cutting feed (per revolution, per minute), Feedrate clamp, Override (Rapid traverse, Cutting feed, External override, 2nd override, Override cancel) Automatic acceleration/deceleration feedrate (Linear acc./dec., Time constant), Constant tangential speed control, Dry run	
Multi-Tasking machine control	Continuous control of 2nd spindle, In-phase matching, Axes torque control	
	–	*Tool-tip point control, *3-dimensional tool compensation
Program registration	256, *512, *960 2MB, *8MB (user area 7.7MB)	
Display	19 inch color SXGA TFT	
NC display languages	English, German, French, Italian, Spanish, Dutch, Norwegian, Swedish, Finnish, Danish, Portuguese, Turkish, Polish, Czech, Romanian, Bulgarian, Chinese (simplified), Chinese (traditional), Korean, Slovakian, Russian, Hungarian, Japanese (simplified language switching)	
Windows languages	English, Chinese (simplified / traditional), Korean, Russian, Japanese (Selection)	
Data Input / Output	USB, *CF card	
Protocol	*MAZAK protocol, Network protocol	
Interface	Card BUS, Ethernet (100BASE-TX), *Profibus-DP, *Ethernet/IP, *SPRINT I/F, *CC-Link	
Spindle function	S-code output (8-digit binary output, Analog output, Actual revolution speed binary output), Constant surface speed, Spindle revolution control (RPM clamp, high speed indication / speed change detection, Rotary speed display), Spindle override (0 - 150%), Multiple orient	
Tool function	T-code output (8-digit binary data, next tool, used tool), Tool life monitoring (Number of workpieces, Time and wear compensation) Spare tool exchange, Tool management (Group number, Pocket number)	
Tool compensation	Tool-tip R compensation, Tool wear compensation, Tool length compensation, Tool diameter compensation	
Number of registered tools	Max. 4000 (Depends on machine specifications)	
Tool offset pairs	4000 (Depends on machine specifications)	
Miscellaneous functions	M-code output (M3 - digit), simultaneous output of four 3-digit M-codes, Second miscellaneous functions (B 3-digit output), High speed MSTB interface	
Coordinate system control	MAZATROL coordinate system	Machine coordinate system (Machine coordinate system, Machine coordinate system shift, Zero-point shift) Work coordinate system (Work coordinate system, Work coordinate system shift)
Manual operation	Rapid traverse, Cutting feed, Handle feed, Zero-point return, Manual control (machine lock, gear shift, barrier cancel), Manual spindle control (spindle start, stop, reverse, jogging)	
Automatic operation	Memory operation, MDI operation, Cycle start, NC reset, Single block, Feed hold, Single process, Optional block skip, Optional stop, Machine lock, Barrier cancel, Feed override, Spindle control, Dry run, Manual handle control, Tool path storage (TPS)	
	–	Hard disk memory operation, *Ethernet operation, *IC memory card operation
Background function	During automatic operation (Programming, Data input / output, Tool path check)	
Machine compensation	Backlash compensation, Pitch error compensation, Rotational axis pitch error compensation, Thermal distortion compensation, Geometric deviation compensation, *Space error compensation	
Protection function	Emergency stop, Over travel, Barrier (stored stroke limit, chuck barrier, 2nd spindle chuck barrier, tailstock barrier, tool barrier), Interlock (cutting start, axis interlock), Alarm, Virtual Machining, MAZAK VOICE ADVISER, INTELLIGENT SAFETY SHIELD	
Measuring function	Coordinates measurement, Tool tip measurement, Automatic measurement (Tool set measurement, External measurement), Measurement data printout	

*: Option

MACHINE SPECIFICATIONS

QUICK TURN NEXUS SERIES

		BED LENGTH	QUICK TURN NEXUS 100-II MS	QUICK TURN NEXUS 100-II MSY	QUICK TURN NEXUS 100-II MY	QUICK TURN NEXUS 200-II	QUICK TURN NEXUS 200-II M	QUICK TURN NEXUS 200-II MS
Capacity	Maximum Swing		21.65 in / 550 mm	21.65 in / 550 mm	21.65 in / 550 mm	24.02 in / 610 mm	26.50 in / 675 mm	26.50 in / 675 mm
	Maximum Bar Work Capacity		2 in / 51 mm	2 in / 51 mm	2 in / 51 mm	2.6 in / 65 mm	2.6 in / 65 mm	2.6 in / 65 mm
	Maximum Machining Diameter		11 in / 280 mm	11 in / 280 mm	11 in / 280 mm	13.78 in / 350 mm	14.75 in / 380 mm	14.75 in / 380 mm
	Maximum Machining Length	20	17.875 in / 455 mm	17.875 in / 455 mm	15.125 in / 455 mm	20.161 in / 511 mm	21.285 in / 538 mm	22.701 in / 575 mm
40		--	--	--	40.534 in / 1031 mm	41.660 in / 1058 mm	--	
60		--	--	--	60.275 in / 1531 mm	61.284 in / 1558 mm	--	
Main Spindle	Chuck Size		6 in	6 in	6 in	8 in	8 in	8 in
	Maximum Speed		6000 rpm	6000 rpm	6000 rpm	5000 rpm	5000 rpm	5000 rpm
	Motor Rating		30	30	30	30	30	30
	Motor Output (30 minute rating)		15 hp	15 hp	15 hp	35 hp	35 hp	35 hp
		11 kw	11 kw	11 kw	26 kw	26 kw	26 kw	
Second Spindle	Chuck Size		5 in	5 in	--	--	--	6 in
	Maximum Speed		6000 rpm	6000 rpm	--	--	--	6000 rpm
	Motor Rating		30	30	--	--	--	30
	Motor Output (30 minute rating)		15 hp	15 hp	--	--	--	10 hp
		11 kw	11 kw	--	--	--	8 kw	
Turret (Upper)	Number of Tools		12	12	12	12	12	12
	Maximum Speed		4500 rpm	4500 rpm	4500 rpm	--	4500 rpm	4500 rpm
	Motor Rating		5	5	5	--	5	10
	Motor Output (5 minute rating)		5 hp	5 hp	5 hp	--	7.5 hp	7.5 hp
		4 kw	4 kw	4 kw	--	6 kw	6 kw	
Feed Axes	Travel (X Axis)		7.25 in / 185 mm	7.25 in / 185 mm	7.25 in / 185 mm	8.75 in / 225 mm	9.00 in / 230 mm	9.00 in / 230 mm
	Travel (Y Axis)		--	4 in / 100 mm	4 in / 100 mm	--	--	--
	Travel (Z Axis)	20	17.88 in / 455 mm	17.88 in / 455 mm	15.13 in / 385 mm	21.13 in / 535 mm	22.75 in / 575 mm	22.61 in / 575 mm
		40	--	--	--	41.50 in / 1055 mm	41.13 in / 1095 mm	--
		60	--	--	--	61.13 in / 1555 mm	62.75 in / 1595 mm	--
Travel (W Axis)		18 in / 460 mm	18 in / 460 mm	--	--	--	23.00 in / 585 mm	

MACHINE SPECIFICATIONS

QUICK TURN NEXUS SERIES

		BED LENGTH	QUICK TURN NEXUS 200-II MSY	QUICK TURN NEXUS 200-II MY	QUICK TURN NEXUS 250-II	QUICK TURN NEXUS 250-II M	QUICK TURN NEXUS 250-II MS	QUICK TURN NEXUS 250-II MSY	QUICK TURN NEXUS 250-II MY
Capacity	Maximum Swing		26.50 in / 675 mm	26.50 in / 675 mm	24.04 in / 610 mm	26.50 in / 675 mm	26.50 in / 675 mm	26.50 in / 675 mm	26.50 in / 675 mm
	Maximum Bar Work Capacity		2.6 in / 65 mm	2.6 in / 65 mm	3.0 in / 77 mm	3.0 in / 77 mm	3.0 in / 77 mm	3.0 in / 77 mm	3.0 in / 77 mm
	Maximum Machining Diameter		14.75 in / 380 mm	14.75 in / 380 mm	13.78 in / 350 mm	14.75 in / 380 mm	14.75 in / 380 mm	14.75 in / 380 mm	14.75 in / 380 mm
	Maximum Machining Length	20	22.701 in / 575 mm	21.285 in / 538 mm	18.733 in / 475 mm	19.858 in / 504 mm	21.275 in / 541 mm	21.275 in / 541 mm	19.858 in / 504 mm
40		--	41.660 in / 1058 mm	39.108 in / 995 mm	40.358 in / 1024 mm	--	--	40.358 in / 1024 mm	
60		--	61.284 in / 1558 mm	58.858 in / 1495 mm	59.858 in / 1524 mm	--	--	59.858 in / 1524 mm	
Main Spindle	Chuck Size		8 in	8 in	10 in	10 in	10 in	10 in	10 in
	Maximum Speed		5000 rpm	5000 rpm	4000 rpm	4000 rpm	4000 rpm	4000 rpm	4000 rpm
	Motor Rating		30	30	30	30	30	30	30
	Motor Output (30 minute rating)		35 hp	35 hp	35 hp	35 hp	35 hp	35 hp	35 hp
		26 kw	26 kw	26 kw	26 kw	26 kw	26 kw	26 kw	
Second Spindle	Chuck Size		6 in	--	--	--	6 in	6 in	--
	Maximum Speed		6000 rpm	--	--	--	6000 rpm	6000 rpm	--
	Motor Rating		30	--	--	--	30	30	--
	Motor Output (30 minute rating)		10 hp	--	--	--	35 hp	10 hp	--
		8 kw	--	--	--	26 kw	8 kw	--	
Turret (Upper)	Number of Tools		12	12	12	12	12	12	12
	Maximum Speed		4500 rpm	4500 rpm	--	4500 rpm	4500 rpm	4500 rpm	4500 rpm
	Motor Rating		10	30	--	10	10	10	10
	Motor Output (5 minute rating)		7.5 hp	7.5 hp	--	7.5 hp	7.5 hp	7.5 hp	7.5 hp
		6 kw	6 kw	--	6 kw	6 kw	6 kw	6 kw	
Feed Axes	Travel (X Axis)		9.00 in / 230 mm	9.00 in / 230 mm	8.75 in / 225 mm	9.00 in / 230 mm	9.00 in / 230 mm	9.00 in / 230 mm	9.00 in / 230 mm
	Travel (Y Axis)		4.00 in / 102 mm	4.00 in / 102 mm	--	--	--	4.00 in / 102 mm	4.00 in / 102 mm
	Travel (Z Axis)	20	22.63 in / 575 mm	22.75 in / 575 mm	20.25 in / 515 mm	22.75 in / 570 mm	22.63 in / 575 mm	22.63 in / 575 mm	22.75 in / 570 mm
		40	--	41.13 in / 1095 mm	40.75 in / 1035 mm	43.13 in / 1095 mm	--	--	43.13 in / 1095 mm
		60	--	62.75 in / 1595 mm	60.50 in / 1535 mm	62.75 in / 1595 mm	--	--	62.75 in / 1595 mm
Travel (W Axis)		23.00 in / 585 mm	--	--	--	23.00 in / 585 mm	23.00 in / 585 mm	--	

MACHINE SPECIFICATIONS

QUICK TURN NEXUS SERIES

		BED LENGTH	QUICK TURN NEXUS 300-II	QUICK TURN NEXUS 300-II M	QUICK TURN NEXUS 350-II	QUICK TURN NEXUS 350-II M	QUICK TURN NEXUS 350-II MSY	QUICK TURN NEXUS 350-II MY
Capacity	Maximum Swing		26.77 in / 680 mm	29.50 in / 750 mm	26.77 in / 680 mm	29.50 in / 750 mm	29.50 in / 750 mm	29.50 in / 750 mm
	Maximum Bar Work Capacity		3.0 in / 77 mm	3.0 in / 77 mm	4.0 in / 102 mm	4.0 in / 102 mm	4.0 in / 102 mm	4.0 in / 102 mm
	Maximum Machining Diameter		16.540 in / 420 mm	16.540 in / 420 mm	16.540 in / 420 mm	16.540 in / 420 mm	18.000 in / 460 mm	16.540 in / 420 mm
	Maximum Machining Length	26	25.834 in / 654 mm	25.834 in / 654 mm	23.800 in / 603 mm	23.800 in / 603 mm	25.687 in / 650 mm	23.800 in / 603 mm
		60	62.710 in / 1589 mm	62.710 in / 1589 mm	60.720 in / 1538 mm	60.720 in / 1538 mm	62.250 in / 1585 mm	60.720 in / 1538 mm
80		82.860 in / 2104 mm	82.860 in / 2104 mm	80.920 in / 2053 mm	80.920 in / 2053 mm	--	80.920 in / 2053 mm	
Main Spindle	Chuck Size		10 in	10 in	12 in	12 in	12 in	12 in
	Maximum Speed		4000 rpm	4000 rpm	3300 rpm	3300 rpm	3300 rpm	3300 rpm
	Motor Rating		30	30	30	30	30	30
	Motor Output (30 minute rating)		35 hp	35 hp	40 hp	40 hp	40 hp	40 hp
			26 kw	26 kw	30 kw	30 kw	30 kw	30 kw
Second Spindle	Chuck Size		--	--	--	--	10 in	--
	Maximum Speed		--	--	--	--	4000 rpm	--
	Motor Rating		--	--	--	--	30	--
	Motor Output (30 minute rating)		--	--	--	--	35 hp	--
		--	--	--	--	26 kw	--	
Turret (Upper)	Number of Tools		12	12	12	12	12	12
	Maximum Speed		--	4000 rpm	--	3300 rpm	4000 rpm	4000 rpm
	Motor Rating		--	4	--	4	4	4
	Motor Output (5 minute rating)		--	10 hp	--	10 hp	10 hp	10 hp
			--	8 kw	--	8 kw	8 kw	8 kw
Feed Axes	Travel (X Axis)		10.13 in / 260 mm	10.13 in / 260 mm	10.13 in / 260 mm	10.13 in / 260 mm	11.00 in / 280 mm	10.13 in / 260 mm
	Travel (Y Axis)	26	--	--	26.38 in / 670 mm	--	6.00 in / 150 mm	6.00 in / 150 mm
		60	--	--	63.25 in / 1605 mm	--	6.00 in / 150 mm	6.00 in / 150 mm
		80	--	--	83.50 in / 2120 mm	--	--	6.00 in / 150 mm
	Travel (Z Axis)	26	26.38 in / 670 mm	26.38 in / 670 mm	25.50 in / 645 mm	26.38 in / 670 mm	26.38 in / 670 mm	26.38 in / 670 mm
		60	63.25 in / 1605 mm	63.25 in / 1605 mm	62.38 in / 1580 mm	63.25 in / 1605 mm	63.25 in / 1605 mm	63.25 in / 1605 mm
		80	83.50 in / 2120 mm	83.50 in / 2120 mm	82.50 in / 2095 mm	83.50 in / 2120 mm	--	83.50 in / 2120 mm
	Travel (W Axis)	26	--	--	--	--	25.63 in / 650 mm	--
		60	--	--	--	--	62.25 in / 1585 mm	--

MACHINE SPECIFICATIONS

QUICK TURN NEXUS SERIES

		BED LENGTH	QUICK TURN NEXUS 400-II	QUICK TURN NEXUS 400-II M	QUICK TURN NEXUS 400-II MY	QUICK TURN NEXUS 450-II	QUICK TURN NEXUS 450-II M	QUICK TURN NEXUS 450-II MY
Capacity	Maximum Swing		33.27 in / 845 mm	33.27 in / 845 mm	33.07 in / 840 mm	33.27 in / 845 mm	33.27 in / 845 mm	33.07 in / 840 mm
	Maximum Bar Work Capacity		4.0 in / 102 mm	4.0 in / 102 mm	4.0 in / 102 mm	7.24 in / 184 mm	7.24 in / 184 mm	7.24 in / 184 mm
	Maximum Machining Diameter		23.000 in / 580 mm	23.000 in / 580 mm	23.000 in / 580 mm	23.000 in / 580 mm	23.000 in / 580 mm	23.000 in / 580 mm
	Maximum Machining Length	40	40.395 in / 1022 mm	40.395 in / 1022 mm	--	38.690 in / 979 mm	38.690 in / 979 mm	--
80		81.770 / 2072 mm	81.770 in / 2072 mm	82.880 in / 2105 mm	80.065 in / 2029 mm	80.065 in / 2029 mm	82.830 in / 2005 mm	
120		123.020 in / 3123 mm	123.020 in / 3123 mm	125.580 in / 3155 mm	121.315 in / 3080 mm	121.315 in / 3080 mm	121.250 in / 3080 mm	
Main Spindle	Chuck Size		12 in	12 in	12 in	24 in	24 in	24 in
	Maximum Speed		2500 rpm	2500 rpm	2500 rpm	2000 rpm	2000 rpm	2000 rpm
	Motor Rating		30	30	30	30	30	30
	Motor Output (30 minute rating)		50 hp	50 hp	50 hp	50 hp	50 hp	50 hp
		37 kw	37 kw	37 kw	37 kw	37 kw	37 kw	
Second Spindle	Chuck Size		--	--	--	--	--	--
	Maximum Speed		--	--	--	--	--	--
	Motor Rating		--	--	--	--	--	--
	Motor Output (30 minute rating)		--	--	--	--	--	--
		--	--	--	--	--	--	
Turret (Upper)	Number of Tools		12	12	12	12	12	12
	Maximum Speed		--	4000 rpm	4000 rpm	--	4000 rpm	4000 rpm
	Motor Rating		--	4	4	--	4	4
	Motor Output (5 minute rating)		--	10 hp	10 hp	--	10 hp	10 hp
		--	8 kw	8 kw	--	8 kw	8 kw	
Feed Axes	Travel (X Axis)		12.13 in / 310 mm	12.13 in / 310 mm	13.38 in / 340 mm	12.13 in / 310 mm	13.38 in / 340 mm	13.38 in / 340 mm
	Travel (Y Axis)	40	--	--	--	--	--	--
		80	--	--	8.00 in / 200 mm	--	--	8.00 in / 200 mm
		120	--	--	8.00 in / 200 mm	--	--	8.00 in / 200 mm
	Travel (Z Axis)	40	42.13 in / 1070 mm	42.13 in / 1070 mm	--	42.13 in / 1070 mm	42.13 in / 1070 mm	--
		80	83.50 in / 2120 mm	83.50 in / 2120 mm	83.63 in / 2125 mm	83.50 in / 2120 mm	83.50 in / 2120 mm	83.63 in / 2125 mm
120		124.75 in / 3170 mm	124.75 in / 3170 mm	125.00 in / 3175 mm	124.75 in / 3170 mm	124.75 in / 3170 mm	125.00 in / 3175 mm	

A CONTINUOUS COMMITMENT TO MANUFACTURING GROWTH AND PRODUCT ADVANCEMENT

Mazak has been continuously growing and advancing its Florence, Kentucky-based Manufacturing Facility since opening the doors in 1974. And it is this ongoing investment in its operations that enables the company to effectively support the ever-evolving technology demands of its customers across all industry segments.

Today, Mazak uses a Production-On-Demand approach to build its machine tools, which includes the QUICK TURN NEXUS Series of machines. This lean manufacturing philosophy gives the company extreme production agility to quickly address current market trends, as well as meet every type of machining requirement.

Production-On-Demand also allows Mazak to shorten its production lead times and minimize inventory levels, ensuring each machine coming off the line incorporates the latest, most innovative technology.



UNMATCHED SUPPORT RESOURCES FOR MAXIMIZING MACHINE INVESTMENTS

Whether you are new to CNC machining or a seasoned journeyman machinist, Mazak works closely with each of its customers to increase their productivity, efficiency and equipment utilization, and does so through its Technology Centers and Optimum Plus total support program.

ADVANCED TECHNOLOGY NETWORK

Mazak's eight Technology Centers throughout North America provide customers with easy access to the latest, most advanced manufacturing systems for optimizing their part-production processes. Customers can also take advantage of each location's industry expertise, training programs and application resources to achieve improved throughput, shorter production lead times and increased profitability.

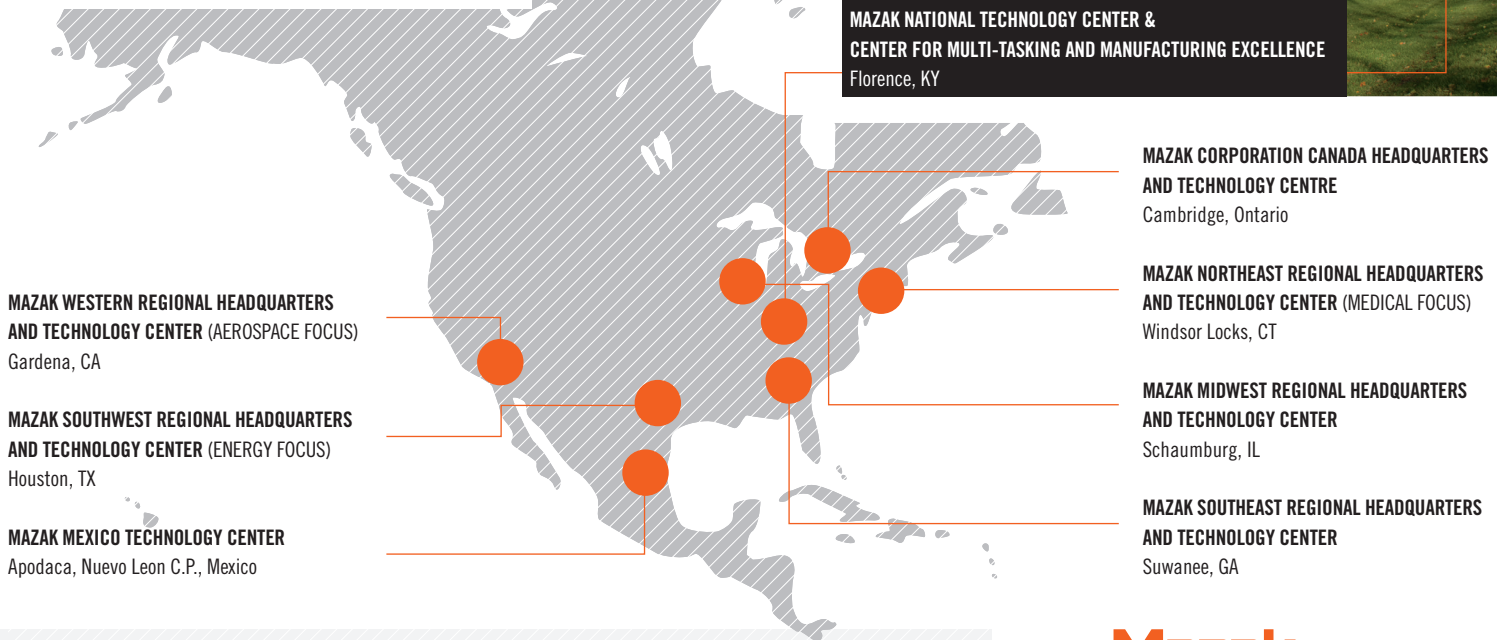

COMPLETE CUSTOMER SUPPORT

Through its Optimum Plus program, Mazak offers the best, most comprehensive customer service in the industry, from machine and CNC control technical support to fast spare parts fulfillment to progressive learning courses.



Every Mazak machine comes with a comprehensive warranty, free technical phone support and software upgrades for the entire life of the product.



Mazak has one of the industry's largest inventories of spare parts, ensuring 97% same-day shipping on orders.

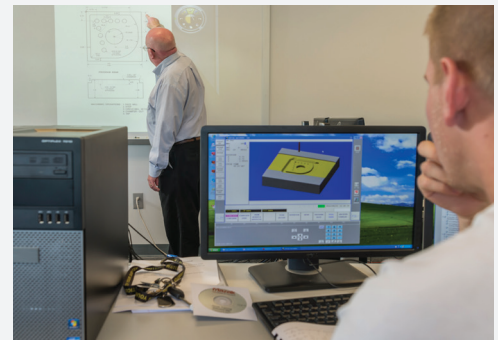

Mazak partners with its customers to train them on how to achieve the highest levels of productivity and profitability.

Mazak

www.mazakusa.com

MAZAK CORPORATION
NORTH AMERICAN MANUFACTURING HEADQUARTERS
8025 Production Drive, Florence, KY 41042
Tel: (859) 342-1700 Fax: (859) 342-1865

09_13_SER_QTN_B